

Motorized Linear Actuator

baelz 373-E07



BA_373-E07_02_DEF_MJ_3619

Table of Contents

1. SAFETY	4
1.1 Intended use	4
1.2 Instructions for the operator	4
1.3 Personnel	5
1.4 Before starting work	5
1.5 During operation	5
1.5.1 Transport, installation and assembly	5
1.5.2 Maintenance and repair	5
1.6 Working environment	5
2. PRODUCT DESCRIPTION	6
2.1 Identification	6
2.2 Motorized linear actuator	6
2.3 Technical Specifications	7
2.4 Options and Extras	8
2.5 Type name	8
2.6 Operating conditions	9
3. TRANSPORT AND STORAGE	9
4. ASSEMBLY	10
4.1 Fitting position	10
4.2 Assembly with the valve	11
4.3 Principle of operation	12
4.3.1 Manual adjustment	12
4.4 Electrical connection	13
4.5 Carrying out the electrical connection	13
5. COMMISSIONING	14
5.1 Test run	14
5.1.1 Checking the direction of rotation	14
6. RETROFITTING OF OPTIONAL EXTRAS	15
6.1 Fitting a potentiometer	15
6.2 Fitting 2 additional, travel-dependent limit switches (2EZ)	16
6.2.1 Adjusting the switching points	17
6.3 Fitting a potentiometer to the 2EZ assembly	18

7. DIGITAL POSITIONER 7020	19
7.1 Intended use	19
7.2 Operational modes and operating options	20
7.2.1 Standard operation using DIP switches	20
7.2.2 Standard operation using Modbus VT100 or direct addressing	20
7.2.3 Modbus mode	20
7.2.4 Normal and safety modes	20
7.2.5 Safety mode: freeze protection and excessive temperature	20
7.2.6 3-point control with a continuous output signal	21
7.3 Wiring diagrams and terminal allocation	22
7.3.1 Wiring diagrams	22
7.3.2 Terminal allocation	23
7.4 Configuration of the DIP switches	24
7.4.1 Details on DIP switches	25
7.5 Commissioning	27
7.5.1 Quick start guide	27
7.5.2 Initialization run	27
7.5.3 Meaning of LED signals	28
7.6 Errors	29
7.6.1 Errors after an initialization run	29
7.6.2 Errors during normal positioner operation	30
7.7 Technical Specifications	31
7.8 Accessories and options	31
8. SPARE PARTS	32
9. DECOMMISSIONING AND DISPOSAL	34
10. TROUBLESHOOTING	34
10.1 Checklist for operational malfunctions	35
11. DIMENSIONAL DRAWINGS	36

1. SAFETY

Read these operating instructions, in particular the following safety instructions, carefully before installation and operation.



Beware

Beware

Potentially hazardous situation that could result in minor injury.
Also indicates a hazard that may result in property damage.



Caution

Caution

Potentially harmful situation in which the product or an object in its vicinity may be damaged.



Danger

Danger

Imminent danger of death or serious injury.



Warning

Warning

Potentially hazardous situation that may result in death or serious injury.



Tip:

Application instructions and other useful information.

1.1 Intended use

Baelz 373-E07 motorized linear actuators are controlled by three-point control or constant control in combination the digital positioner baelz 7020. The linear actuators of the series described in this document are intended for the stroke adjustment of valves.

To ensure their intended use, make sure that the above type identification complies with the nameplate of the linear actuators before starting any activities. The actual technical specifications of the linear actuators and the power supply requirements are the specifications indicated on the nameplate.

Any use other than the intended use mentioned above, different tasks, and operation with other power sources than those permitted, is considered to be improper use. In case of improper use, the operator shall be solely liable for the risk presented to persons and the device as well as other property!

Intended use also includes compliance with accident prevention and DIN VDE regulations as well as safe working practices for all measures described in these operating instructions, taking into account the usual technical regulations.

1.2 Instructions for the operator

Always keep the operating instructions available at the place where the actuator is used!

During installation, operation and maintenance, observe the applicable occupational safety, accident prevention and DIN VDE regulations. If necessary, observe additional regional, local or internal safety regulations.

Make sure that every person entrusted with one of the measures described in these operating instructions has read and understood these instructions.

1.3 Personnel

Only qualified personnel may work on this linear actuator or in its vicinity. Qualified persons are deemed to be persons who are familiar with the installation, assembly, commissioning and operation or maintenance of the actuators and have the appropriate qualifications for their job. Necessary or prescribed qualifications include, but are not limited to:

- Training / instruction and the authorization to switch electric circuits and devices / systems on and off in accordance with EN 60204 (DIN VDE 0100 / 0113) and the technical safety standards
- Training or instruction in the care and use of appropriate safety and work protection equipment in accordance with safety technology standards.
- First aid training.

Work in a safe manner and avoid any operation that would endanger the safety of persons or damage the linear actuator or other property in any way.

1.4 Before starting work

Before carrying out any work, check whether the types specified here correspond to the information on the name plate of the actuator:

baelz 373-E07

1.5 During operation

Safe operation is only possible if transport, storage, assembly, operation and maintenance is carried out in a safe, proper and professional manner.

1.5.1 Transport, installation and assembly

Observe the general installation and safety regulations for heating, ventilation, air conditioning and piping systems. Use tools only for their intended purpose. Wear the required personal and other protective equipment.

1.5.2 Maintenance and repair

Prior to maintenance or repair, make sure that the linear actuator is disconnected from power by qualified personnel in accordance with DIN VDE standards. The E07 is a low maintenance linear actuator. Depending upon usage, it may be necessary to occasionally grease the actuator spindle with „Gleitmo 805“.

1.6 Working environment

Note the information on working environment in the technical specifications.

2. PRODUCT DESCRIPTION

2.1 Identification

Each actuator has a nameplate showing specifications regarding the maximum operating conditions of the device and a unique, order-related serial number.

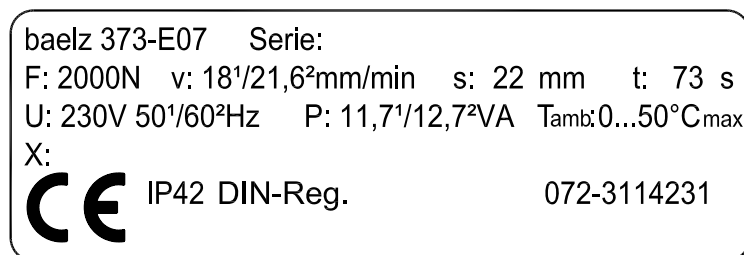

Fig. 1: Baelz nameplate for motorized actuators

Table 1. Key to nameplate, baelz 373-E07

		serial number of actuator
Serie		
F	N	actuating force
v	mm/min	actuator speed
s	mm	stroke
t	s	stroke time
U	V / Hz	supply voltage
P	VA	power consumption
Tamb	°C	ambient temperature
X		built-in extras (eg. potentiometer)
IP42		ingress protection rating acc. to EN 60529
superscript ¹ and ²		Actuator speed and power consumption depend on supply frequency (Hz).

2.2 Motorized linear actuator

The baelz 373-E07 is a motorized linear actuator with load-dependent limit switches. The actuators are designed for highly accurate positioning in an industrial environment. They come complete with a manual adjustment device and a wide range of options and additional extras is available.

2.3 Technical Specifications

		Table 2. Technical Specifications, baelz 373-E07		
		E07-20-06-S21/L	E07-20-18-S21/L	E07-07-130-S21/L
Actuating force	N	2000	2000	700
Positioning speed ¹⁾	mm/min	6	18	130
Supply voltage ²⁾		24 V / 115 V / 230 V 50/60 Hz ± 10 %		
Power consumption (230 V) VA		11.7		
Operating mode acc. to IEC 34-1		S1 - 100 %		
Type of motor		synchronous motor (syn)		
Motor protection		stall-proof motor (B))		
Maximum stroke	mm	44		
Cable glands		3x M20 x 1,5		
Electrical connection		internal terminal block, see wiring diagram for terminal allocation		
Limit switches		2 load-dependent limit switches, max. 250 V AC, max. 6 A		
Fitting position		as required, but not "head down" with the actuator below the valve		
Ambient temperature	°C	0 to +50		
Position indicator		position of spindle coupling relative to indicator marks on yoke		
Manual adjustment		with (yellow) release button and manual adjuster		
IP-rating according to EN 60529		IP 42		
Trapezoidal thread		Tr 10 x 3		
Connection type		yoke S21 / S21-L		
Weight, approx.	kg	2,2		

1) At 60 Hz the positioning speed and power consumption both increase by 20 %.

2) Other supply voltages available upon request. Configuration options are indicated in the Baelz price list.

2.4 Options and Extras

Table 3. Options and Extras, baelz 373-E07

Option / Extra	Description	Remarks
2EZ-V2	2 limit switches with position indicator	
Mf-FgA	Multiturn potentiometer	A= 200 Ω, 5 kΩ, 1 kΩ Please specify resistance when ordering
2EZ-V2-FgA	2 limit switches with position indicator and feedback potentiometer	
7164-230	Built-in microprocessor controller	including potentiometer 1-5 kΩ Supply : 24 V / 115 V / 230 V 50/60 Hz order to match actuator!
7164-115		
7064-24		
7020-230	Digital positioner	Input / output signal: 0(2)...10 V / 0(4)...20mA factory setting 0...10 V Includes 5 kΩ feedback potentiometer Supply : 24 V / 115 V / 230 V 50/60 Hz
7020-115		
7020-24		
MP373-E07-S21-L	Ständeraufbau für Armaturen mit Spindel-Ø 16 mm	Surcharge on top of basic price of 373-E07...S21
MP373-E07-Silf	Silicone-free version	
MP373-E07-KT9992	Mechanical travel limits	
MP373-E07-RH	Locking manual override	
MP373-E07-IP65	Ingress protection rating IP65	
MP373-E07-2RC	2 additional RC snubbers	Fitted in actuator E07..., 230 V

2.5 Type name

baelz 373	-	E07	-	20	-	18	-	S21
motorized linear actuator		actuator type		thrust		positioning speed		yoke type

2.6 Operating conditions

The actuators are suitable for installation in industrial plants and in waterworks and power plants with a low pollutant concentration.

When used outdoors, the actuator must be protected with an additional cover against

- rain
- direct sunlight
- strong draughts
- dust

3. TRANSPORT AND STORAGE



Risk of injury caused by failure to observe safety regulations!

Caution

- Wear the required personal and other protective equipment.
- Protect the linear actuator from impact, shock, vibration and similar influences.
- Store the linear actuator (or the complete actuator/valve assembly) in a dry place.
- Observe the transport and storage temperature limits of -20 to +60°C.

4. ASSEMBLY



Make sure that the specifications on the nameplate correspond to those in the order documents!

4.1 Fitting position

When fitting with the connecting rod in horizontal position, fit the linear actuator such that the sides of the yoke are positioned one above the other in the vertical plane.

- Allow for about 140 mm space above the cover at the site of installation.
- Check the work environment before fitting the actuator and putting it into operation:
- Make sure that the valve is correctly installed. For detailed information, refer to the valve's installation instructions.
- Determine the mounting position of the linear actuator. Do not mount linear actuators "head down" below the valve.

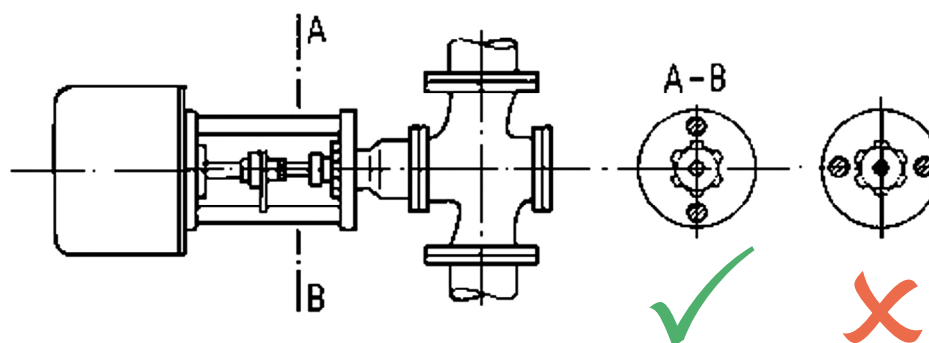

Fig. 2: Fitting position

4.2 Assembly with the valve

Prior to assembly, check that:

- the operating conditions comply to the specifications of the linear actuator.
- the valve is complete (yoke on actuator or on valve).
- the connections on valve and actuator match.

The linear actuator is supplied with the spindle retracted.

A slight adjustment for fitting of the coupling can be carried out by turning the spindle.

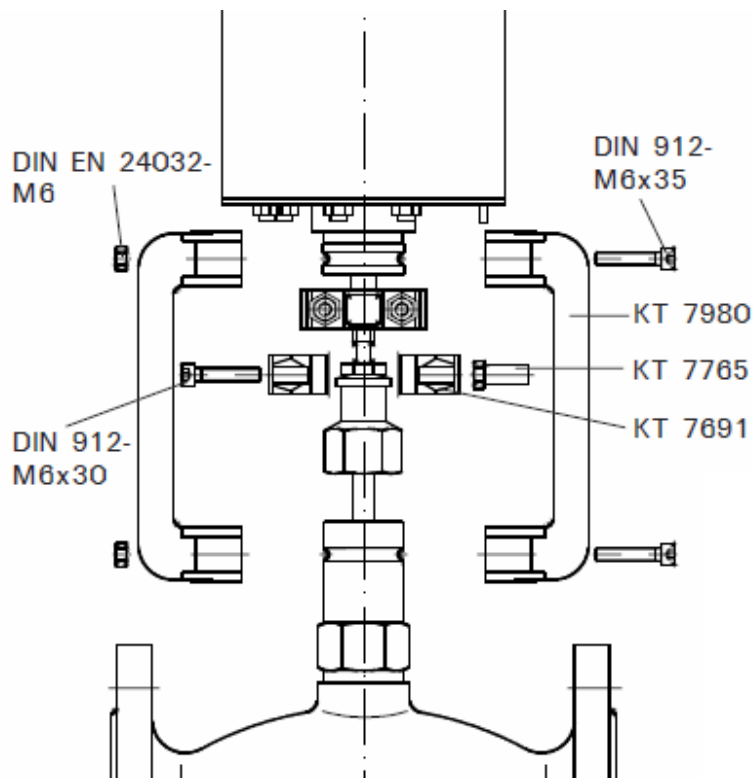

Fig. 3: Assembly with the valve

Ensure that the connecting rod of the actuator and the valve spindle are correctly aligned. Misalignment can lead to power loss and premature wear. When supplied with integrated potentiometer assembly, adjustment of the assembly may be necessary.

4.3 Principle of operation

Motorized linear actuators to operate control valves for flow regulation applications in control and process technology. The self-locking threaded spindle/spindle nut is driven by an electric motor via a gearbox. This converts the rotary movement into a linear movement. Load-dependent limit switches dictate the end positions

4.3.1 Manual adjustment

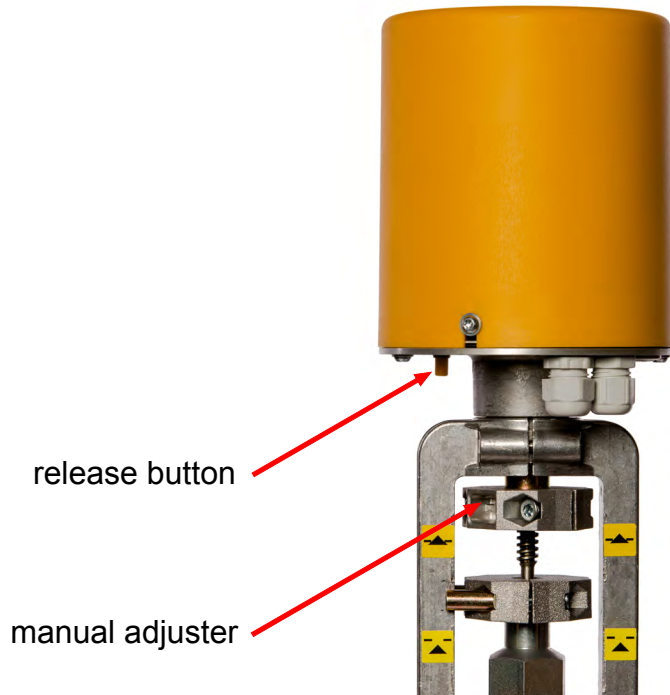

Manual adjustment may only be carried out when the motor is not in motion. To adjust, press and hold the yellow release button and turn the manual adjuster until the desired position is reached. As soon as the yellow release button is no longer depressed, the actuator follow the signal from a control system or a built-in positioner.

 **Tip:** If the manually set position is to be maintained, ensure that the input signal from the control system or positioner is deactivated.

4.4 Electrical connection



Risk of electric shock!

Danger

Use an appropriate power supply to ensure that no hazardous voltage can enter the device during normal operation or in the event of a system failure or defective system components.

Failure to heed this warning may result in death, serious injury or substantial material damage.

For short-circuit protection and disconnection of the actuator from the power supply, fuses and switch disconnectors must be provided on site. The current values for the rating depend on the operating current of the motor (refer to the nameplate).

The electrical connection should only be carried out by trained, qualified personnel.

- Prior to connection, observe the instructions in this chapter.
- After connection, but before applying voltage, observe the instructions in the chapter "Commissioning" (page 14).
- When making the electrical connection, be sure that the power supply is turned OFF! Ensure protection against unintentional reconnection to the power supply!
- For wiring and connection, observe the regulations for the construction of electric power installations and the regulations of the local energy supplier!
- Check compliance of the supply voltage and frequency with the specifications on the nameplate of the actuator and on the nameplate of the actuator motor.
- Always select the cable cross section so as to match the actuator's power consumption and the required cable length. Minimum cross section of the cable for this linear actuator: 1 mm²

In case of malfunction:

Dangerous voltage if protective earth conductor is NOT connected! Risk of electric shock!

→ Do not operate the device if the protective earth conductor is not connected!

Trapped wires can lead to short circuiting! Risk of electric shock and malfunction.

4.5 Carrying out the electrical connection



Risk of electric shock!

Danger

→ Disconnect the device from the power supply before removing cover.

Always use the wiring diagram on the inside of the cover or supplied with the actuator.

Replace the dummy plugs with cable glands.

1. Strip the cable as necessary.
2. Strip the ends of the individual wires.
3. For flexible wires: Use wire end ferrules as specified in DIN 46228.
4. Connect the wires as shown in the job-specific wiring diagram.

The IP-rating shown on the nameplate is only valid if suitable cable glands are used.

5. COMMISSIONING



Warning

Pay attention to moving parts during fitting and adjustment. Risk of injury and substantial material damage.



Attention

Actuators which are supplied fitted with a valve are set to the appropriate valve stroke length. When an actuator with a 7020 digital positioner is fitted to a valve, an initialization run must be carried out to set up the actuator according to the valve type.

5.1 Test run

5.1.1 Checking the direction of rotation

- Adjust the actuator manually to roughly the middle position.
- In direction of travel CLOSE, switch the actuator on and watch the direction of rotation.
- If the direction of rotation is wrong, switch off immediately.
- Check wiring (jumpers).
- Repeat the test run.



Danger

Risk of electric shock!

If the switches in the actuator are not factory-wired, check proper switching off in end positions: ***With the cover removed, the linear actuator may only be operated briefly for test runs or when performing absolutely essential adjustments on electrical components, such as potentiometer, limit switches or positioning electronics.***

While performing this activity, there is unobstructed access to hazardous, live, exposed, moving and rotating parts. Adjustments performed incorrectly or without exercising the necessary caution may result in death, serious injury or substantial material damage. Any operation of the linear actuator with the cover removed for a purpose other than that described above is prohibited.

6. RETROFITTING OF OPTIONAL EXTRAS



Danger

Disconnect actuator from power supply before starting work!

6.1 Fitting a potentiometer

Set consists of:

- 1x potentiometer, 200 Ω , 1 k Ω or 5 k Ω
- 1x Torx screw T20



Fig. 4: E07 actuator with cover removed

- To remove the actuator cover, loosen the 2 Torx T20 flanged button screws slightly and lift off the cover (see Fig. 4, above).
- Set the valve / actuator to the 50% position (see section 4.3.1 on manual adjustment)
- Set the potentiometer to the 50% position. To do this, turn the potentiometer shaft until an endstop is reached, then turn it back by 5 rotations (of 10 in total).
- Fit the potentiometer spring into the slot in the white plastic insert, so that the potentiometer sits flush on the actuator and the potentiometer mounting hole is aligned with the mounting hole in the actuator (see Fig. 5, below.).

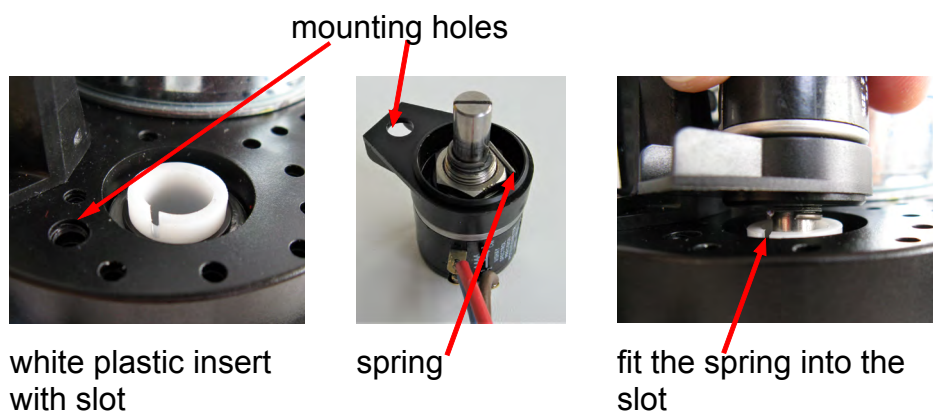

Fig. 5: Aligning the potentiometer

- Fix the potentiometer with the Torx T20 button screw (Fig. 6, below)
- Lay the wiring between motor and terminal block assembly and wire the potentiometer up: terminal 91 = red, terminal 92 = brown, terminal 93 = blue (Fig. 7, below). Trim the ferrules if necessary.
- Secure the wiring with cable ties.



Fig. 6: Fixing the potentiometer

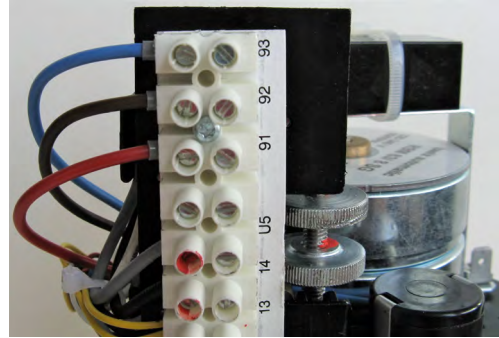

Fig. 7: Wiring the Potentiometer

6.2 Fitting 2 additional, travel-dependent limit switches (2EZ)

Set consists of:

- 1x pinion
- 1x 2EZ assembly
- 3x Torx T10 button screws

Table 4. Number of gear teeth in 2EZ assembly depending on valve stroke			
Valve stroke	12	16	22
Number of teeth, pinion	z = 11	z = 9	z = 7
Number of teeth, gear	z = 65	z = 67	z = 68

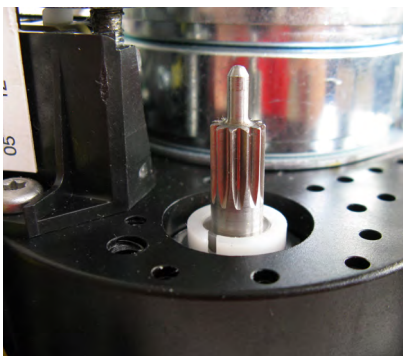

Fig. 8: Pinion



Fig. 9: 2EZ assembly



Fig. 10: Pinion fits here

- Fit the pinion into the white plastic insert on the actuator so that the raised part in the base of the insert fits into the slot on the lower end of the pinion (Fig. 8).
- Take a look at where the pinion fits into the underside of the 2EZ assembly (Fig. 10).



Fig. 11: Put this screw into place before fitting



Fig. 12: 2EZ assembly on E07 actuator



Fig. 13: Tighten the screws

- Put one of the 3 Torx T10 button screws into place, as access here is difficult when the 2EZ assembly is in place, see Fig. 11.
- Fit the 2EZ assembly onto the acutator so that the raised lip around the pinion hole sits in the hole on the actuator and the 3 fixing holes in the 2EZ assembly are aligned with the fixing holes in the actuator (Fig. 12).
- Fix the 2EZ assembly with the 3 Torx T10 button screws (Fig. 13).

6.2.1 Adjusting the switching points

The 2EZ assembly has two pairs of cams, each of which activates a switch. For each switch, two switching points can be set using its cam pair. In order to set the desired switching points, set the actuator to the first position and adjust one of the two cams so that it activates the switch in this position (Fig. 14). If required, this process may be repeated with a second actuator position and the other cam in the pair. Wire up the outputs E1-E3 or E4-E6 (wiring diagram Fig. 15).



Fig. 14: Adjusting the switching cams

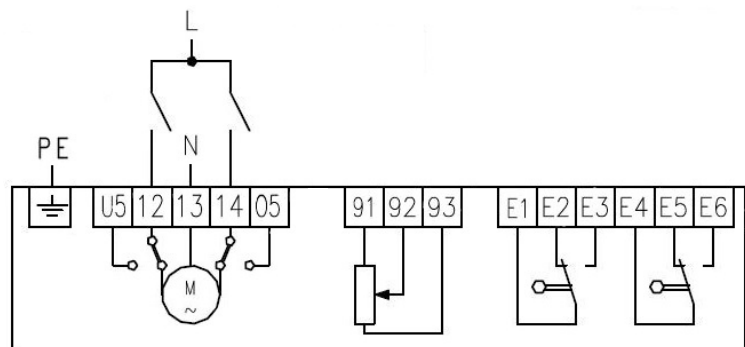

Fig. 15: Wiring diagram baelz 373-E07 with 2EZ and potentiometer

6.3 Fitting a potentiometer to the 2EZ assembly

Material:

- 1x Potentiometer assembly, 200 Ω , 1 k Ω oder 5 k Ω (Fig. 16).

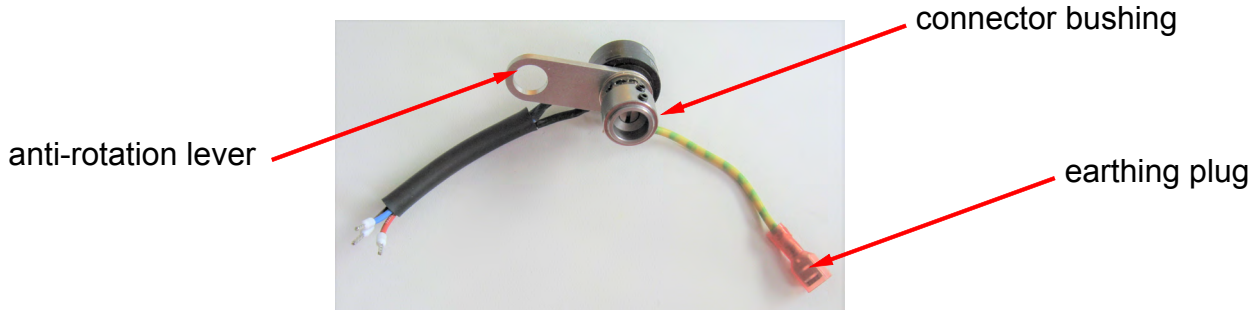

Fig. 16: Potentiometer assembly for 2 additional travel limit switches

- Set the valve / actuator to the 50% position (see section 4.3.1 on manual adjustment)
- Set the potentiometer to the 50% position. To do this, turn the potentiometer shaft until an endstop is reached, then turn it back by just under half a rotation (of just under one rotation in total).
- Place the potentiometer assembly onto the spindle of the 2EZ assembly, inserting the black plastic sleeve of the 2EZ assembly into the hole in the anti-rotation lever. Connect the earthing plug to the small metal connector next to the motor (Fig. 17).

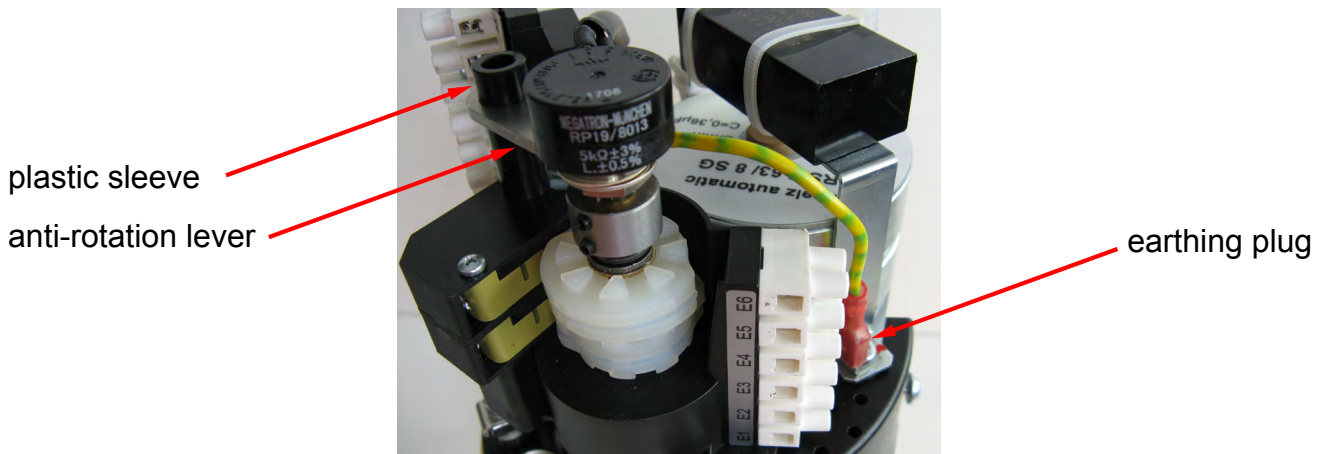

Fig. 17: Fitting a potentiometer to the 2EZ assembly

- Tighten the lower grub screw in the connector bushing with a 1.5 mm Allen key. Check that the top grub screw is tight. Do not loosen the top grub screw.
- Connect the potentiometer to the terminal block of the actuator: terminal 91 = red, terminal 92 = brown, terminal 93 = blue (Fig. 19, below). Trim the ferrules if necessary.

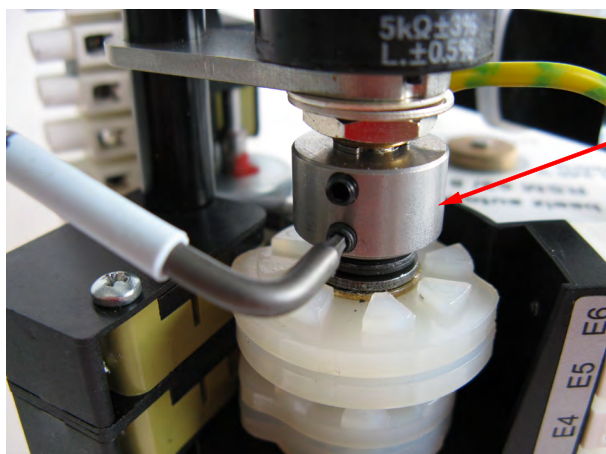

Fig. 18: Fixing the potentiometer with the lower grub screw

connector bushing

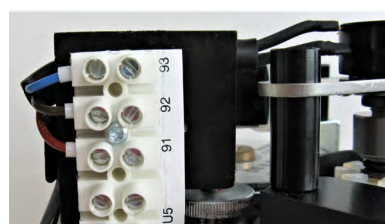

Fig. 19: Wiring the potentiometer

7. DIGITAL POSITIONER 7020

7.1 Intended use

The digital positioner **baelz 7020** controls the actuator according to the value of the control signal: 0(2)-10 V, 0(4)-20 mA

To ensure use for the purpose intended, check that the above type identification corresponds to the nameplate on the positioner before starting any activities. The technical specifications of the positioner and the power supply requirements are indicated on the name plate. Any use other than the intended use stated above, use for different tasks, and operation with other power sources than those permitted, is considered to be improper use. In case of improper use, the operator shall be solely liable for the risk presented to persons and to the device as well as to other property!

The intended use also comprises compliance with the accident prevention regulations and the DIN VDE standards of the German Institute for Standardization and the Association for Electrical, Electronic & Information Technologies. It also implies working in accordance with the safety requirements when performing all activities described in these operating instructions, under consideration of general technical rules and regulations.

7.2 Operational modes and operating options

 **Tip:** For further information and additional functions, see baelz 7020 operating instructions.

7.2.1 Standard operation using DIP switches

The DIP switches can be used to carry out standard configurations and operations (see section 7.4).

When DIP switch 11 is set to 0, the 7020 is in the standard operational mode.

In standard mode, all DIP switches are active and the functions of the Baelz 7020 can be individually adapted. Functions which are predefined and unalterable in standard mode are described in chapter 6.1 of the baelz 7020 operating instructions.

7.2.2 Standard operation using Modbus VT100 or direct addressing

In standard mode, the Baelz 7020 can be operated using Modbus VT100. For this, a virtual 7020 display and a virtual 7020 keypad are transmitted to a user interface. Modbus direct addressing, e.g. from a building automation system, enables access to status information and allows operation and configuration. (See baelz 7020 operating instructions, Appendix A). The settings given by the DIP switches remain active. Values which are only relevant in Modbus mode can be adjusted in standard mode, but only take effect in Modbus mode.

7.2.3 Modbus mode

When DIP switch 11 is set to 1, the Baelz 7020 is in Modbus mode. In Modbus mode, the 7020 is at its most flexible and can be configured and operated using either a Modbus VT100 or Modbus direct addressing, for example in a building automation system. See separate operating instructions "Baelz 7020 Digital Positioner - Operating Instructions for Modbus mode"

7.2.4 Normal and safety modes

In normal mode the position of the valve is controlled by the set value at analogue input AI2. The N↔S switch shown in the picture on the right is set to normal mode (N). In normal mode, no external control systems can be connected to terminals 12 and 14.



Fig. 20: N↔S-switch

7.2.5 Safety mode: freeze protection and excessive temperature

In safety mode the actuator can be sent to a safe position (extended / retracted, depending on the direction of action of the valve) in case of failure or malfunctioning of the microcontroller.

To operate the Baelz 7020 in connection with an external freeze protection and/or excessive temperature thermostat, set the N↔S switch to safety mode (S).

Connect the freeze protection and/or excessive temperature thermostat according to desired function and priority. Be sure to take the direction of action into account! See wiring diagrams in the baelz 7020 operating instructions.

7.2.6 3-point control with a continuous output signal

1. Set the positioner up and wire to power supply as described previously and initialize as described in section 7.5.2.
2. Set the N↔S switch (Fig. 20, page 20) to "S"
3. Wire as shown in Fig. 21 (the positioner must remain connected to the power supply throughout).
4. The required signal can now be picked up on AO1 and AO2.

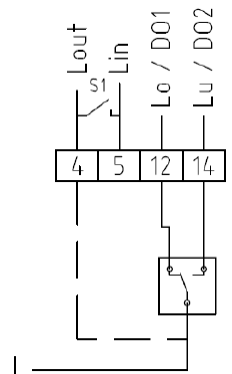

Fig. 21: Wiring diagram 3-point-signal

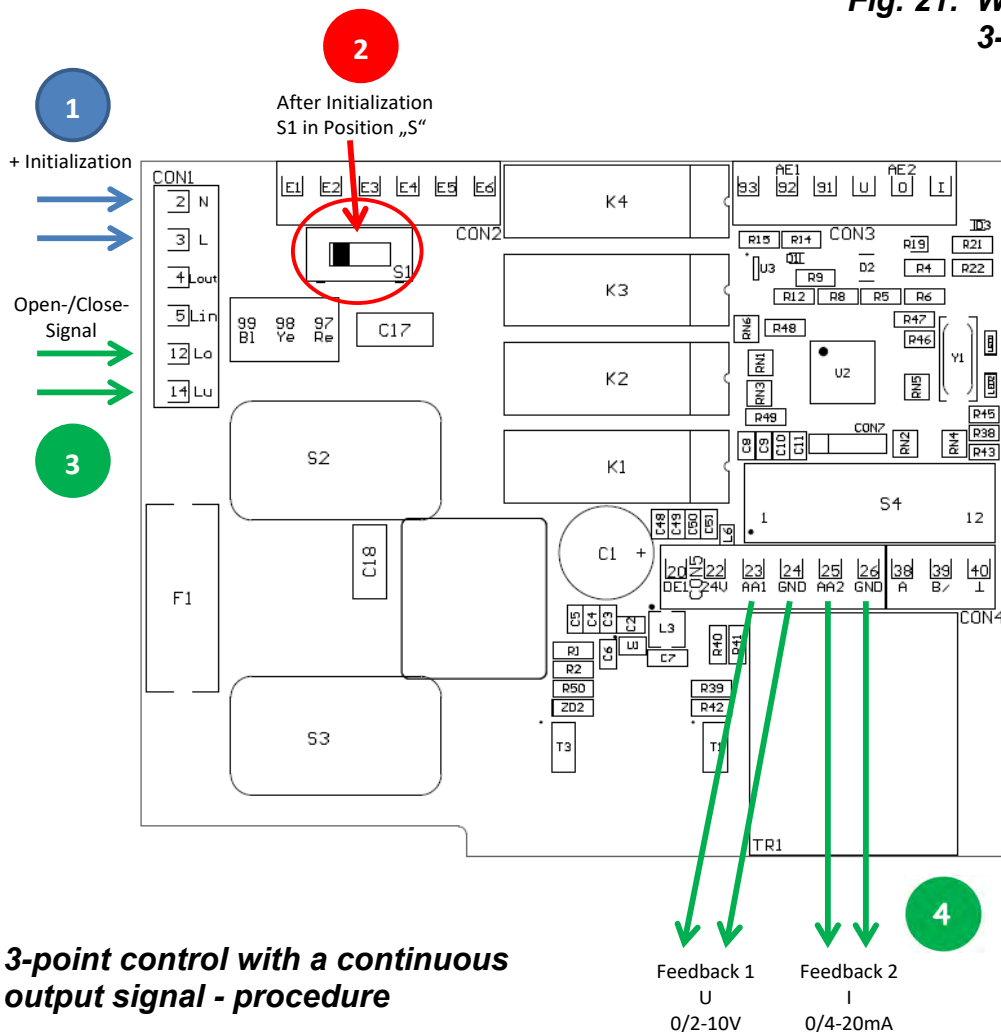

Fig. 22: 3-point control with a continuous output signal - procedure



Danger of destroying the actuator!

Before any further re-initialization of the device, disconnect terminals 12 and 14 and set the N↔S switch to normal operation (N).



Tip:

An error signal showing on the red LED has no effect on the function of the positioner. Should you wish to deactivate the error signal anyway, set the DIP-switch 11 to 1 ("ON") and change the following values in the menu item "CA" using WinBas Tools (on PC, see baelz 7020 operating instructions):

- AD to 0
- EFP to 0.0%
- LA to 1

7.3 Wiring diagrams and terminal allocation



Danger

Disconnect actuator from power supply before starting work.
See also section 4.4.

7.3.1 Wiring diagrams

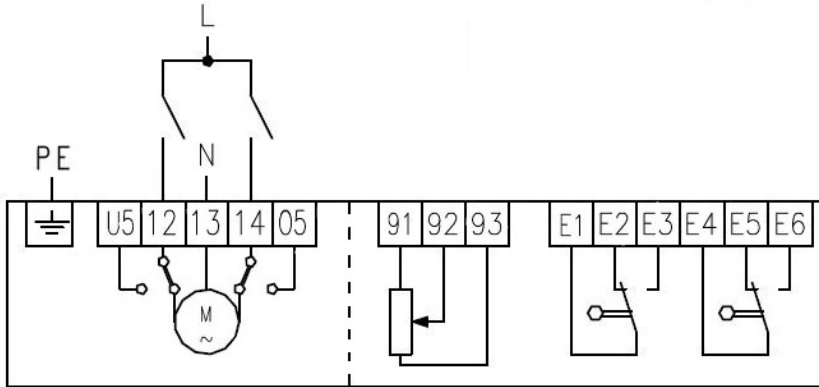

Fig. 23: Wiring diagram basic actuator baelz 373-E07 with potentiometer (Fg) and 2 additional limit switches (2EZ) as optional extras

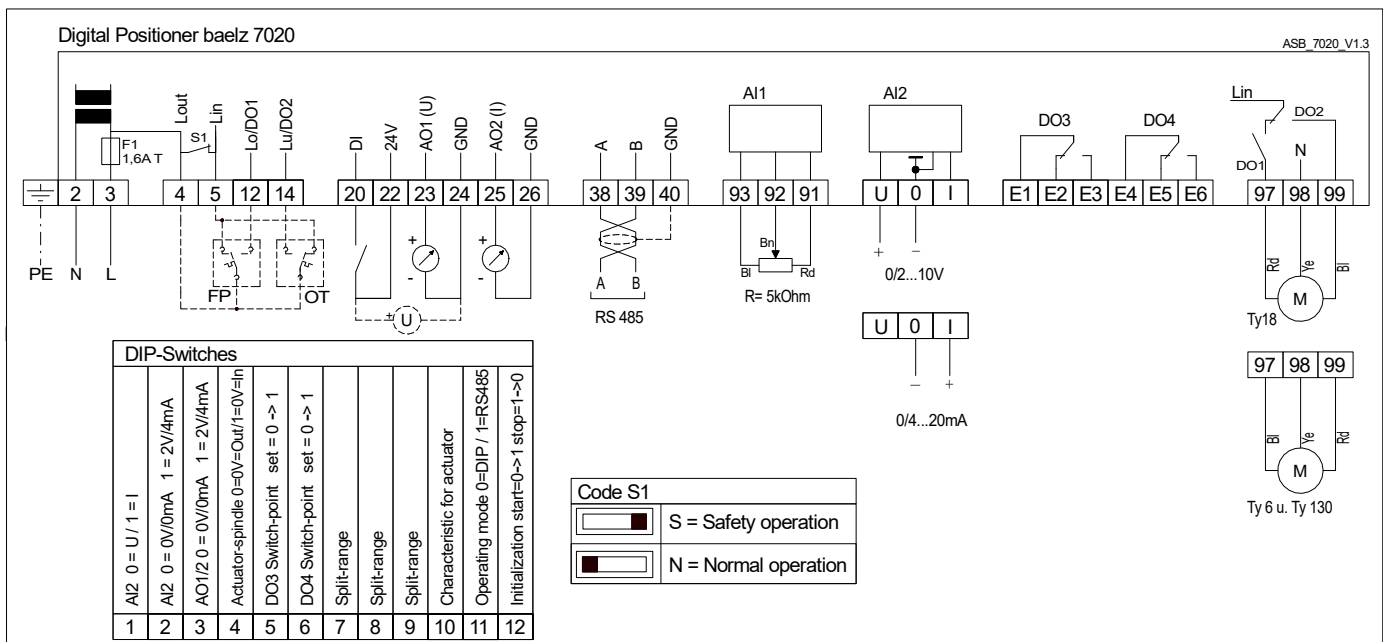

Fig. 24: Wiring diagram digital positioner baelz 7020

7.3.2 Terminal allocation

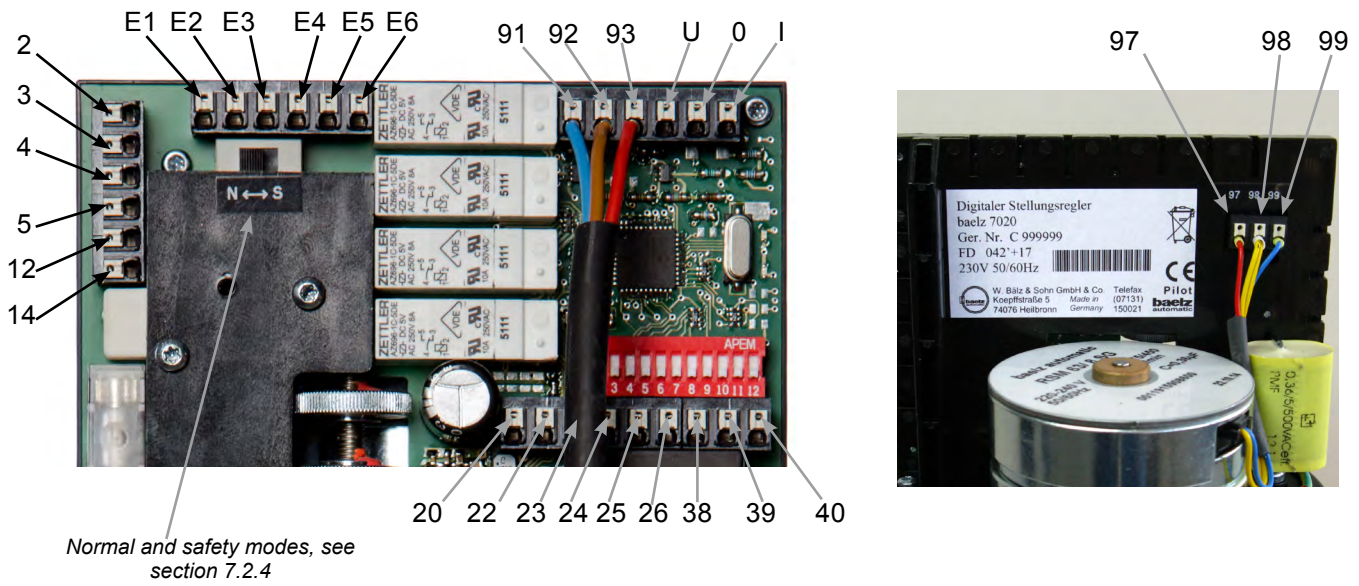
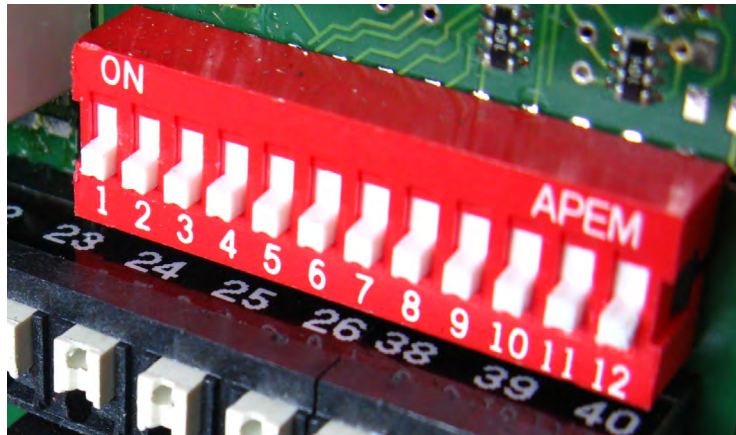

Fig. 25: Terminal numbering

Table 5. Terminal allocation		
Terminal	Allocation	Notes
2, 3	supply terminals	See wiring diagram on page 22 for correct allocation.
4, 5, 12, 14	Can be allocated to an overriding external control system (freeze protection, excessive temperatures).	For external control, the N↔S switch must be set to „S“ (safety mode).
20, 22	Digital input for a switch used to select between two conditions, e.g. „open / closed“ or „summer / winter“.	
23, 24, 25, 26	Analogue output position indicator using voltage and / or current.	Analogue outputs can be connected simultaneously.
38, 39, 40	Connection terminals for Modbus	
91, 92, 93	Connection terminals for potentiometer	
U, 0, I	Input setpoint value for valve position	IMPORTANT! Position of DIP switch 1, see section 7.4
E1, E2, E3, E4, E5, E6	Terminals for 2 digital outputs	IMPORTANT! Position of DIP switches 5 & 6, see section 7.4
97, 98, 99	Connection terminals for motor	Factory wiring varies according to type of actuator

BA_373-E07_02_DEF_MJ_3619

7.4 Configuration of the DIP switches



The factory setting of the DIP switches is position 0, as shown.





Switch	Function	Position 1 "ON"	Position 0 
DIP 1	Set value input: voltage, V or current, mA?	current, mA	voltage, V
DIP 2	Set value input starting at 0 V / 0 mA or 2 V / 4 mA?	2-10 V / 4-20 mA	0-10 V / 0-20 mA
DIP 3	Analogue output starting at 0 V / 0mA or 2 V / 4 mA?	2-10 V and / or 4-20 mA	0-10 V and / or 0-20 mA
DIP 4	Direction of control action: valve closed with drive spindle extended or retracted?	Drive spindle retracted → valve closed	Drive spindle extended → valve closed
DIP 5	Current position of the actuator is saved as additional switching position "2EZ-1". See wiring diagram, page 22.		from 0 to 1 → save "2EZ-1"  = 2%
DIP 6	Current position of the actuator is saved as second additional switching position "2EZ-1". See wiring diagram, page 22.		from 0 to 1 → save "2EZ-2"  = 98%
DIP 7, 8, 9	These 3 DIP switches define the function: linear / split range / 11-point / inverted		s. Fig. 27, page 26  = linear
DIP 10	Defines valve characteristic using actuator characteristic, see page 26.	Actuator characteristic inverse equal percentage, valve action linear	Actuator characteristic linear, valve action equal percentage
DIP 11	Selects standard or Modbus mode.	Modbus mode	standard mode
DIP 12	Starts initialization run. Set back to 0 after initialization (s. section 7.5.2)		from 0 to 1 → starts initialization run
N↔S	Selects normal or safety mode	position "S" = safety mode	position "N" = normal mode

Fig. 26: Setting the DIP switches

 factory setting

7.4.1 Details on DIP switches

DIP1 and DIP2:

are interpreted together:

DIP1: 0 = voltage → DIP2: 0 = 0-10 V or 1 = 2-10 V.

DIP1: 1 = current → DIP2: 0 = 0-20 mA or 1 = 4-20 mA.



Attention

Either a voltage source can be connected to the U-terminal or a current source to the I-terminal. Never connect both at the same time.

DIP3:

DIP switch 3 configures the analogue outputs AO1 and AO2 (see wiring diagram, Fig. 24, page 22). DIP switch 3 defines the scaling of the two analogue outputs. When DIP 3 = 0, AO1 is set to 0-10 V and AO2 to 0-20 mA (factory setting), when DIP 3 = 1, AO1 is set to 2-10 V and AO2 to 4-20 mA. In Modbus mode AO1 and AO2 can be configured separately.



Tip:

Using 2-10 V / 4-20 mA enables clear identification of a loss of signal (= 0 V / 0 mA).

DIP4:

DIP switch 4 changes the direction of operation of the actuator.

The direction of operation can only be changed if the unit has been initialized. Until the unit has been initialized, the following setting applies: Valve closed when actuator spindle extended.

There can also be no change in the direction of operation during an initialization run, whether or not the unit was already initialized before starting the current initialization run.

The direction of operation must not be confused with heating/cooling! Heating in standard mode is carried out with DIP switches 7, 8 and 9 set to "0". Cooling in standard mode is carried out with DIP switches 7, 8 and 9 set to "1". Split-range can be combined with heating in standard mode, but not with cooling. In Modbus mode, split-range can be combined with both heating and cooling.

DIP5:

Saves the current position as switching position "2EZ-1" when switched from 0 to 1. No function is assigned to switching from 1 to 0. Even if DIP 5 is left in position 1 when the 7020 positioner is switched on, the current position will not be saved.

DIP6:

Saves the current position as switching position "2EZ-2" when switched from 0 to 1. No function is assigned to switching from 1 to 0. Even if DIP 6 is left in position 1 when the 7020 positioner is switched on, the current position will not be saved.

DIP7, DIP8 and DIP9:

These three DIP switches work together to define the split range function at analogue input 2 (AI2).

FUNCTION	DIP7	DIP8	DIP 9
Linear, 1:1	0	0	0
Split Range: split 50 %, offset 0 %	1	0	0
Split Range: split 50 %, offset 50 %	0	1	0
Split Range: split 33.3 %, offset 0 %	1	1	0
Split Range: split 33.3 %, offset 33.3 %	0	0	1
Split Range: split 33.3 %, offset 66.6 %	1	0	1
11-point characteristic	0	1	1
Inverted: 0 becomes 100 and 100 becomes 0 %	1	1	1

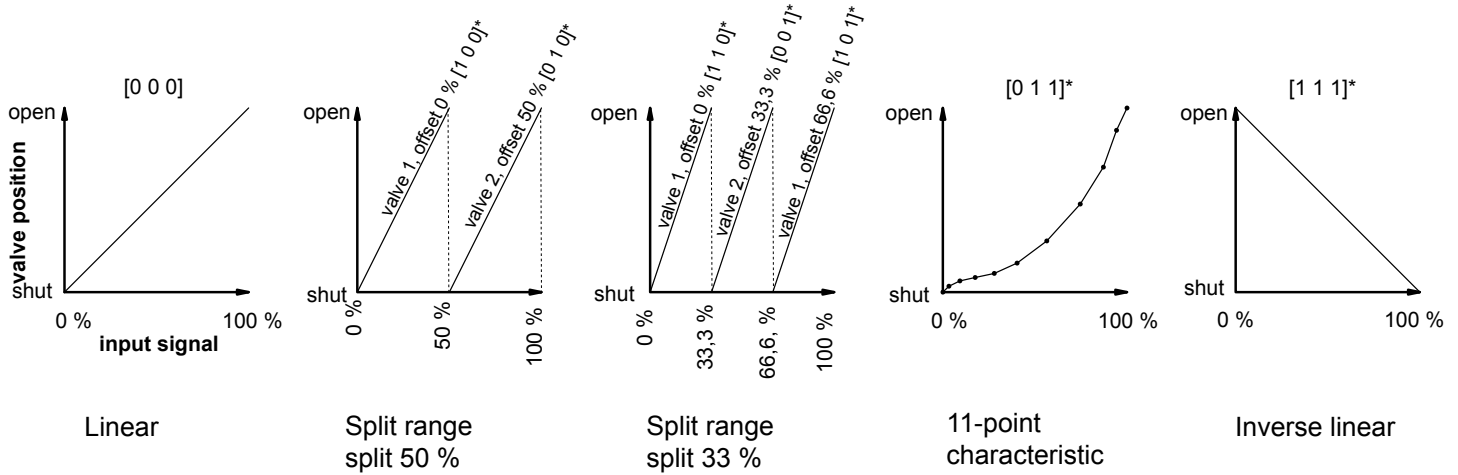

Fig. 27: Graphical illustration of selection of functions by DIP switches 7, 8 & 9

DIP10:

An actuator characteristic can be used indirectly to change a valve characteristic. If, for example, the valve has an equal percentage characteristic, an inverse equal percentage actuator characteristic can be used to generate a resulting linear characteristic, see illustration below.

The actuator characteristic (DIP 10) can also be combined with the characteristics which can be selected using DIPs 7, 8 and 9 (e.g. split range). The microcontroller first processes the characteristic defined by DIPs 7, 8 and 9 and subsequently the characteristic defined by DIP 10.

In Modbus mode, two further actuator characteristics can be selected: equal percentage and quadratic inverse equal percentage.

Desired characteristic	DIP-switch 10	Characteristic of the valve	Characteristic of the actuator	Effective at valve
Equal percentage	1 10			
Quadratic	actuator characteristic only selectable in Modbus mode			
Linear	1 10			
Equal percentage	actuator characteristic only selectable in Modbus mode			
Linear	1 10			

= factory setting

DIP11:

DIP switch 11 defines the mode of operation: 1 = Modbus mode, 0 = standard mode. Standard mode is used to apply predefined normal settings.

DIP12:

Starts an initialization run when switched from 0 to 1. If DIP 12 is left in position 1 when the 7020 positioner is switched on, an initialization run will not be started. As long as DIP 12 is set to 1, errors and alarms occurring during normal positioner operation will not be shown. This enables errors occurring during initialization to be distinguished from errors during normal positioner operation. Switch DIP 12 back to 0 after the initialization run (after having analysed possible error codes) to show any errors occurring in normal positioner operation on the red LED. See also section 7.5.2 "Initialization run".

7.5 Commissioning

7.5.1 Quick start guide

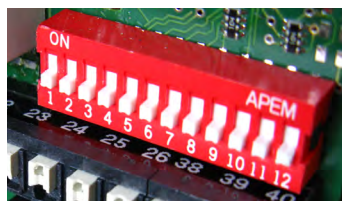

1. Set DIP switches



2. Connect to supply



3. Start initialization run

7.5.2 Initialization run

If the unit is not initialized, the green LED flashes. The red LED is lit when the position of the potentiometer is not ideal for an initialization run. (See section 7.5.3 for meaning of LED signals.) An initialization run can still be carried out, but it will take approx. 1x valve travel time longer. During a successful initialization run, the valve is moved to both of its end positions. The potentiometer and the position of the valve are synchronized and values for valve travel time and switching hysteresis are determined.

Switch DIP switch 12 from 0 to 1 to start an initialization run. The red LED is lit during initialization.

When initialization has been successfully completed, only the green LED is lit. For error signals see table in section "Errors after an initialization run", page 29

As long as DIP switch 12 is set to 1, errors and alarms occurring during normal positioner operation will not be shown. This enables errors occurring during initialization to be distinguished from errors during normal positioner operation.

Switch DIP 12 back to 0 after the initialization run to show any errors occurring in normal positioner operation on the red LED.

(After the first initialization run (unit not previously initialized), the unit moves to the 50% position upon completion of initialization. As soon as DIP 12 is set to 0, the baelz 7020 will follow the set value signal at analogue input 2.)

7.5.3 Meaning of LED signals

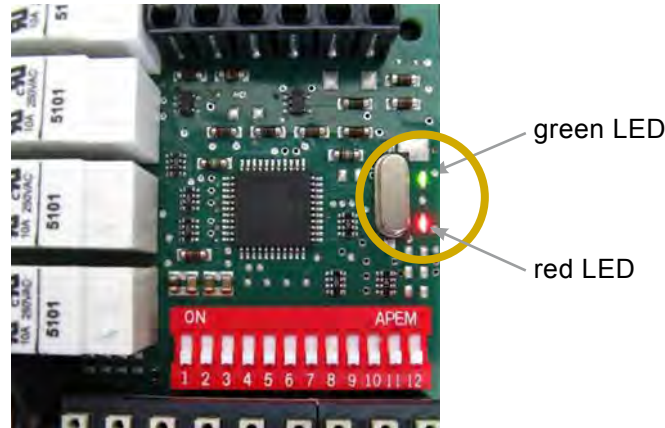

	LED signal	LED signal	Meaning
1	● ●	green off red off	Unit is switched off.
2	● ●	green off red on	Initialization run in progress.
3	★ ●	green flashing red off	Unit is not initialized. Potentiometer in ideal position for initialization run (between 7.5 and 17.5%).
4	★ ●	green flashing red on	Unit is not initialized. Potentiometer not in ideal position for initialization run. Initialization still possible. (If the red LED is flickering, the position of the potentiometer is at the edge of the optimal range and therefore OK.)
5	★ ★	green and red flashing	Error during initialization. Unit is not initialized. The flashing red LED shows the number of the error code: 3 flashes, interval, 3 flashes, interval → error code 3. See also section 7.6.1.
6	● ●	green on red off	Unit is initialized. No errors.
7	● ●	green on red on	Immediately after the unit is switched on, both LEDs are lit for 2 seconds to show that they are in working order.
8	● ★	green on red flashing	Unit is initialized. DIP 12 set to 1 → error after initialization run, see section 7.6.1 DIP 12 set to 0 → error or alarm during normal positioner operation, see section 7.6.2.

7.6 Errors

7.6.1 Errors after an initialization run

Following a successful initialization run, only the green LED is lit.

If the red LED is flashing, this indicates an error following an unsuccessful initialization run.

The first error to occur during initialization is shown. If the green LED is lit, the unit had already been initialized before the current initialization run. If the green LED is flashing, the unit had not been successfully initialized previously.

The red LED shows errors occurring during initialization as follows:

Error code 1: * interval * interval * etc.

Error code 2: ** interval ** interval ** etc.

etc. up to ...

Error code 8: **** interval **** interval **** etc..

Error code	Error	Corrective action
1 → 1 x *	Invalid status of initialization run. Possible cause: EMI (electromagnetic interference).	Remove source of interference.
2 → 2 x **	Sensor malfunction at analogue input AI1: No signal from potentiometer.	Check connection terminals 91, 92, 93 (see wiring diagram, Fig. 24, page 22). Replace potentiometer if necessary.
3 → 3 x ***	Potentiometer value at AI1 too small. Possible cause: EMI.	Remove source of interference. Replace potentiometer if necessary.
4 → 4 x ****	Potentiometer value at AI1 too large. Possible cause: EMI.	Remove source of interference. Replace potentiometer if necessary.
5 → 5 x *****	Wrong direction of travel	Check motor (97, 98, 99) and potentiometer (91, 92, 93) connections (see wiring diagram, Fig. 24, page 22). Remove source of interference.
6 → 6 x *****	Obstruction: potentiometer or motor not moving.	Check connections, set N↔S switch to "N", remove any obstructions.
7 → 7 x *****	Stroke too long.	Fit actuator to a valve with nominal stroke length < 22 mm.
8 → 8 x *****	Stroke too short.	Fit actuator to a valve with nominal stroke length > 8,7 mm, remove any obstructions.

Following an initialization run, the red LED shows only initialization errors as long as DIP switch 12 is set to 1. This enables a clear differentiation between errors occurring during initialization and those occurring during normal positioner operation. Setting DIP switch 12 from 1 back to 0 permits the red LED to show any normal operational errors instead of initialization errors which may have occurred.



BA_373-E07_02_DEF_MJ_3619

7.6.2 Errors during normal positioner operation

The green LED is lit during normal positioner operation.

A flashing red LED shows an error during normal positioner operation. For this, DIP switch 12 must be set to 0.

The red LED indicates errors during normal positioner operation as follows:

( = long flash,  = short flash)

Error code 1:          interval         interval etc.

Error code 2:         interval         interval etc.

etc. up to ...

Error code 6:          interval         interval etc.

Multiple error codes can be displayed simultaneously:

Error codes 3 & 5:           interval       interval

The red LED flashes 10 times between intervals (1.6 s), as a maximum of 10 error codes can be allocated.

The error codes 7 to 10 are not allocated and are reserved for additional alarms.

Error code	Error	Corrective action
1	Sensor malfunction at analogue input AI1: No signal from potentiometer.	Check connection terminals 91, 92, 93 See wiring diagram, Fig. 24, page 22.
2	Sensor malfunction at analogue input AI2: No setpoint signal.	Check connection terminals U, 0, I See wiring diagram, Fig. 24, page 22.
3	Alarm 1: additional switching position (2EZ-1) or other threshold value reached.	Informational alarm: 2EZ-1 is set using DIP 5.
4	Alarm 2: additional switching position (2EZ-2) or other threshold value reached.	Informational alarm: 2EZ-2 is set using DIP 6.
5	Alarm 3: control deviation too large.	Deactivate antifreeze / excessive temp. Re-initialize Baelz 7020.
6	Alarm 4: potentiometer end stops too imprecise or obstruction.	Deactivate antifreeze / excessive temp. Re-initialize Baelz 7020.
7-10	Reserved for as yet undefined alarms 5-8	No error possible.

7.7 Technical Specifications

Table 6. Technical Specifications, baelz 7020

Supply voltage	230 VAC -15 % / +10 %, 50 / 60 Hz, option: 115 VAC 50 / 60 Hz, 24 VAC 50 / 60 Hz
Fuse	internal 1.6 A/T (slow-blow)
Power consumption	approx. 5 VA
IP rating	IP 42
Ambient temperature	0 to 50 °C
Transport / storage temp.	- 25 to +65 °C
Ambient humidity	5 to 90 % relative humidity. (non-condensing)
Dimensions WxHxD	approx. 105 x 82 x 32 mm
DI supply voltage	24 V DC, I _{max} = 5 mA
Digital input	1 configurable using software, I _{max} 5mA, low=0...5VDC, high=9...38VDC, Re=5.5kΩ
Digital outputs	2 potential free auxiliary chageover switches, configurable, max. 250 VAC, 4A min. contact load: 10 V / 100 mA
2 output signals	Output 1: 0/2...10 V / min. ohmic resistance 5kΩ Output 2: 0/4...20 mA / max. ohmic resistance 300Ω Factory setting: 0...10 V and 0...20 mA
Input signal	0/2...10V / Re 63kΩ, 0/4...20mA / Re 200Ω, measurement accuracy 0.1%
Connection	PUSH IN spring terminals, stripping length 8 mm
Wiring	Wire size AWG: min. AWG 24; max. AWG 16 solid wire / stranded wire: min. 0.2 mm ² ; max. 1.5 mm ² with wire ferrule according to DIN 46 228/1: min. 0.25 mm ² ; max. 1.5 mm ² with insulated wire ferrule DIN 46 228/4: min. 0.25 mm ² ; max. 0.75 mm ²
Operation	12 DIP switches / optional: advanced operation using RS485 and software
Interface	RS485 Modbus RTU, Baud rate 2400...19200, 1 start, 8 pieces of data, 1 stop-bit, no parity
Memory	non-volatile semiconductor
Weight	approx. 0.2 kg

7.8 Accessories and options

- Free parameterisation software (Modbus RTU) - Interface RS 485 required!
- For laptops with USB we recommend our interface convertor (Order No. 5280-051).

8. SPARE PARTS

**Fig. 28: Spare parts
baelz 373-E07
all types**

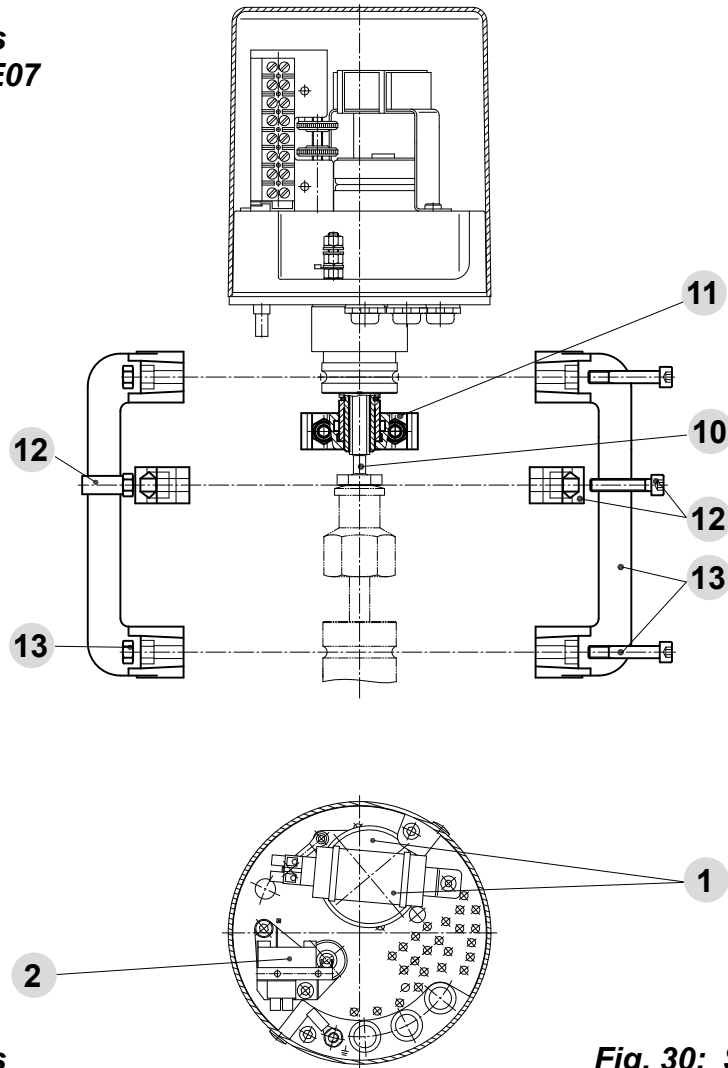

**Fig. 29: Spare parts
baelz 373-E07 type 6**

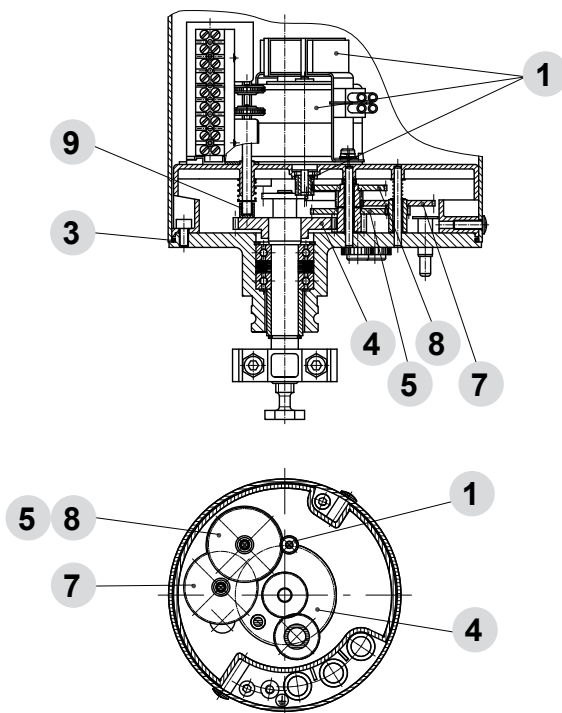

**Fig. 30: Spare parts
baelz 373-E07 type 18**



Tabelle 1. Ersatzteile / Spare parts baelz 373-E07				
Pos.	Bezeichnung	Description	Sachnr. part number	Bestellnr. order number
1	Motoreinheit Typ RSM 63/8 SG einschl.	motor unit type RSM 63/8 SG incl.		
	Motorritzel KT 24669 + Kondensator	motor pinion KT 24669 + capacitor		
	230 V, 50/60 Hz (220-240 V)	230 V, 50/60 Hz (220-240 V)		99373-051
	115 V, 50/60 Hz (110-120 V)	115 V, 50/60 Hz (110-120 V)		99373-053
	24 V, 50/60 Hz	24 V, 50/60 Hz		99373-055
	Kondensator	capacitor		
	0,36 µF / 500 V einschl. 100Ω / 1 W für 115 V, 50/60 Hz (220-240 V)	0,36 µF / 500 V incl. 100Ω / 1 W for 115 V, 50/60 Hz (220-240 V)		99373-711
	1,65 µF / 250 V einschl. 18 Ω / 0,25 W für 115 V, 50/60 Hz (110-120 V)	1,65 µF / 250 V incl. 18 Ω / 0,25 W for 115 V, 50/60 Hz (110-120 V)		99373-712
	36 µF / 63 V für 24 V, 50/60 Hz	36 µF / 63 V for 24 V, 50/60 Hz		99373-713
	2	Endschalter	limit switches	
3	O-Ring	O-ring	Ø120,37x1,78	
4	Zahnraderschaft komplett	gear shaft unit	KS 5440	
5	Trieb 1	gear 1	KS 5217	
6	Trieb 2 (für E07 Typ 18)	gear 2 (for E07 type 18)	KS 5218	
7	Trieb 3 (für E07 Typ 6)	gear 3 (for E07 type 6)	KT 26624	
8	Trieb 4 (für E07 Typ 6)	gear 4 (for E07 type 6)	KT 21635	99373-21635
9	Kappe	cap	KT 26624	
10	Gewindespindel	elevating spindle	KT 21635	99373-21635
11	Handrad komplett	handwheel set		99373-902
	Handradsegment (2x)	handwheel segment (2x)	KT 7691	
	Zylinderschraube (2)	socket head cap screw (2x)	DIN 912 M6x30	K30000269
	Sechskantmutter (2x)	hexagonal nut (2x)	DIN EN 20432 M6	K30000097
12	Kupplung komplett	coupling set		99373-901
	Handradsegment (2x)	hand wheel segment (2x)	KT 7691	
	Zylinderschrauben (2x)	socket head cap screw (2x)	DIN 912 M6x30	K30000269
	Bolzen (2x)	pin (2x)	KT 7765	
13	Ständer S21 komplett	yoke set S21		99373-900
	Ständerelement	yoke element (2x)	KT 7980	
	Zylinderschraube	socket head cap screw (4)	DIN 912 M6x35	K30000584
	Sechskantmutter	hexagonal nut (2)	DIN EN 20432 M6	K30000097

When ordering accessories or spare parts, please note the specifications on the actuator nameplate for essential information regarding actuator and power supply criteria.

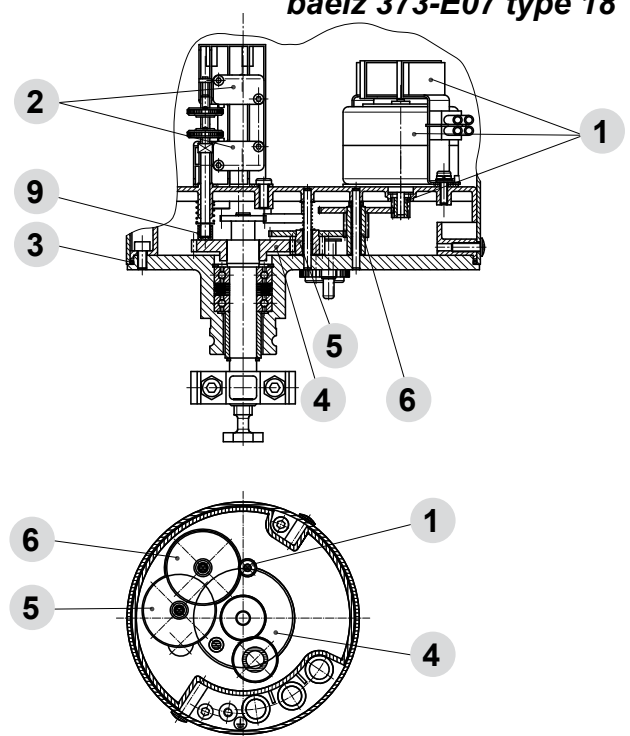

Attention

Risk of damage to actuator due to incorrect or defective spare parts!

All spare parts must comply with the technical requirements as stated by the manufacturer.

- Use only original spare parts!

9. DECOMMISSIONING AND DISPOSAL

Dispose of the digital positioner in accordance with the relevant, country-specific regulations and laws..

10. TROUBLESHOOTING

If the actuator does not work properly, proceed as follows to correct the problem:

1. Check that the actuator is correctly installed.
2. Check the actuator settings and the specifications on the nameplate.
3. Correct the problems as specified in the checklist (page 35).
4. If the problem cannot be corrected, contact the Baelz service department.
5. If, despite consultation, the issue still cannot be resolved, the device can be returned to Baelz for repair / replacement by arrangement with the service department.

Please give the following information when contacting the manufacturer or sending the device in for repair:

- Serial number
- Type name
- Supply voltage and frequency
- Extras fitted
- Error report

10.1 Checklist for operational malfunctions

Malfunction	Cause	Action required
Actuator not working	Power failure	Determine the cause and correct the problem.
	Defective fuse (in control cabinet)	Determine the cause and correct the problem, replace the fuse.
	Linear actuator incorrectly connected	Re-connect as specified on circuit diagram (inside cover).
	Short circuit caused by humidity	Determine the cause, dry the linear actuator; if necessary, replace cover seal and screws and/or fit protective cover.
	Short circuit caused by incorrect connection	Connect correctly.
	Motor winding damage caused, for example, by high voltage or defective electronics	Determine cause, measure current data, compare with nameplate and specifications, dismantle linear actuator and return for repair.
	Voltage drop due to connecting cables being too long and / or having insufficient cross-section	Measure current data with linear actuator, recalculate connecting cables and replace as necessary.
Actuator running erratically, constantly opening and closing	Power fluctuations exceed permissible tolerance	Improve power supply conditions.
	Loose contact in supply line	Check and tighten connections (terminal blocks).
Actuator stops intermittently	Valve jamming	Enable smooth valve movement.
Actuator does not move to end position. Valve fails to open / close	System pressure too high	Adjust system pressure.
	Poor input signal - interfering signals - signal fluctuation	Check input signal at linear actuator, correct the problem causing the malfunction.
Linear actuator fails to move or does not move correctly to the position defined by the input signal.	Circuit board defective	Replace circuit board, if necessary dismantle actuator and return for repair.

11. DIMENSIONAL DRAWINGS

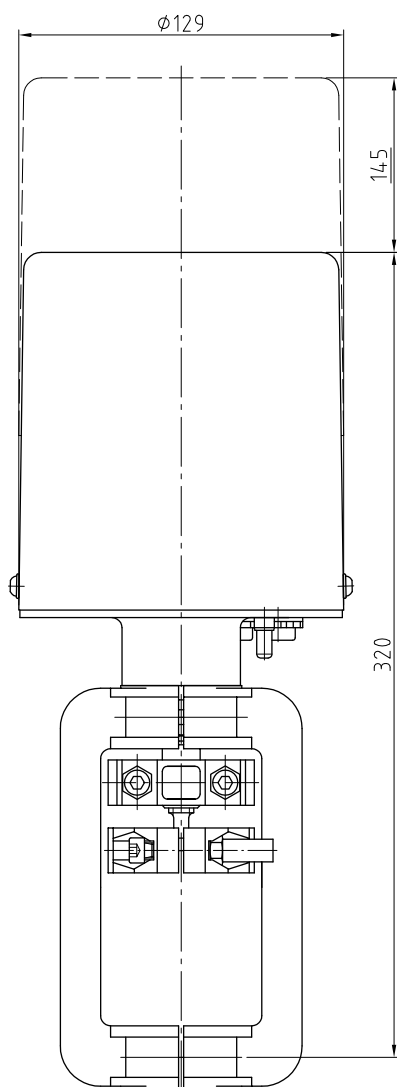

**Fig. 31: Dimensional drawing
baelz E07 with S21 yoke
and spindle Ø 10 mm**

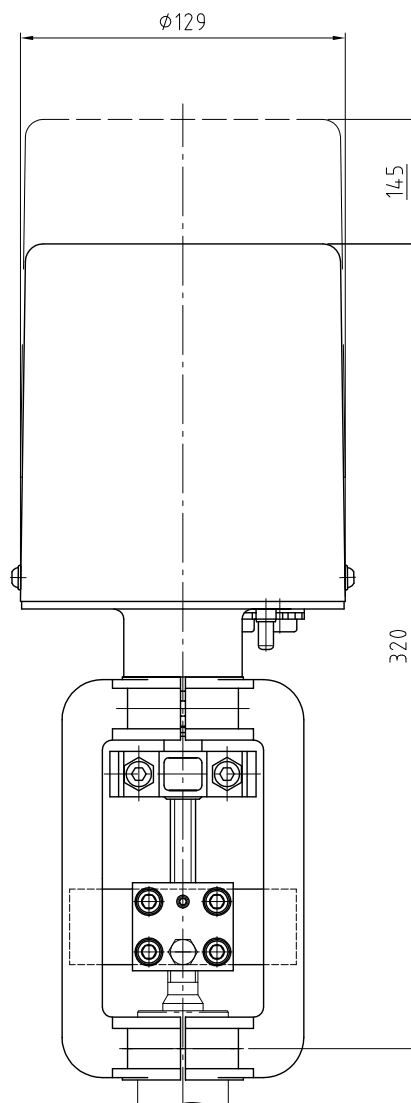

**Fig. 32: Dimensional drawing
baelz E07 with S21-L yoke
and spindle Ø 16 mm**