

VENTOSAS / AIR RELEASE VALVES



VENTOSA DE TRIPLE EFECTO PN16. BRIDA DIN PN-16 AIR RELEASE VALVE 3-FUNCTION PN16. FLANGED DIN PN16



UTILIZACIÓN / APPLICATION :

Conducciones de distribución de agua limpia / *Clean water distribution pipelines.*

Libera grandes volúmenes de aire en el llenado de las tuberías.

Disposal of large volumes of air during fill of the pipes of system.

Agrega gran cantidad de aire al sistema durante la purga de las tuberías.

Add great amount of air to the system during the purge of the pipes.

Liberación de bolsas de aire presurizadas en las tuberías.

Release of pressurized air pockets during operation.



CARACTERÍSTICAS GENERALES / GENERAL CHARACTERISTICS :

Rango desde DN40 hasta DN300 / *Range from DN40 up to DN300 .*

Ventosa de triple función / *Triple function air release valve.*

Partes internas en plástico / *Internal plastic parts .*

Pintura Epoxi 200 micras / *Epoxy paint 200 μm.*

NORMATIVAS / STANDARDS :

Diseño / *Design according to EN 1074-4.*

Pruebas de presión / *Pressure Tests according to EN 12266-1.*

Brida según / *Flange according to PN16 EN 1092-2.*

CONDICIONES DE SERVICIO / WORKING CONDITIONS :

Máxima presión de trabajo / *Maximum Working Pressure : 16 bar.*

Temperatura máxima de trabajo / *Maximum Working Temperature : - 10 °C / + 80 °C.*

MATERIALES / CONSTRUCTION :

No.	Pieza Part	Material Material
1	Cuerpo Body	F.Dúctil GJS500 D.Iron GJS500
2	Guía Flotador Float Guide	ABS
3	Flotador Float	ABS
4	Soporte Support	ABS
5	Asiento Seat Ring	EPDM
6	Soporte Asiento Seat Support	ABS
7	Tapa Cover	F.Dúctil GJS500 D.Iron GJS500
8	Washer Arandela	A.Inox A2 S.Steel A2
9	Tuerca Nut	A.Inox A2 S.Steel A2
10	Tornillo Hexagonal Hexagonal Bolt	A.Inox A2 S.Steel A2
11	Tapa Cowl	F.Dúctil GJS500 D.Iron GJS500
12	Junta Tórica O-Ring	EPDM
13	Cuerpo lateral Side Body	F.Dúctil GJS500 D.Iron GJS500
14	Tapón Cap	Nylon/Latón Nylon/Brass
15	Junta Gasket	EPDM
16	Soporte Bracket	Nylon Nylon
17	Tornillo Ajuste Adjusting Screw	A.Inox A2 S.Steel A2
18	Asiento Seat	EPDM
19	Pasador Hinge Pin	A.Inox A2 S.Steel A2
20	Flotador lateral Side Float	ABS
21	Tornillo Hexagonal Hexagonal Bolt	A.Inox A2 S.Steel A2
22	Washer Arandela	A.Inox A2 S.Steel A2

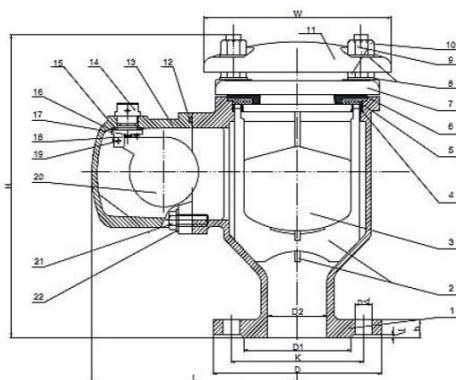

DIMENSIONES / DIMENSIONS :

DN	H	L	D	K	D1	D2	n-d	b	f	W	Peso Weight
40	329	232	150	110	84	40	4-19	19	3	206	20,00
50	329	232	165	125	99	50	4-19	19	3	206	20,00
65	329	232	185	145	118	65	4-19	19	3	206	21,50
80	329	232	200	160	132	80	8-19	19	3	206	22,00
100	413	238	220	180	156	100	8-19	19	3	280	32,20
150	413	238	285	240	211	150	8-23	19	3	280	34,20
200	413	238	340	295	266	150	12-23	20	3	280	38,00
250	413	238	405	355	319	150	12-28	22	3	280	43,90
300	413	238	460	410	370	150	12-28	24,5	4	280	52,90

CURVAS DE ENTRADA-EVACUACIÓN DE AIRE / INFLOW-OUTFLOW AIR CHART :

